

Armarea grinda soclu
Tronson 1 - Sir 1...3

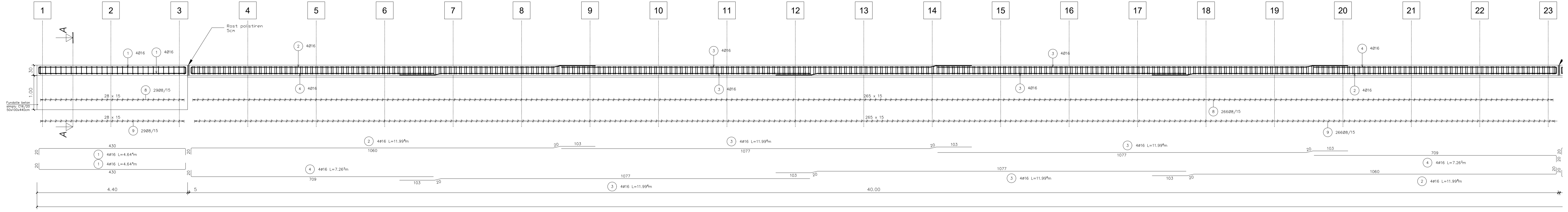

Armarea grinda soclu
Tronson 2 - Sir 4...23

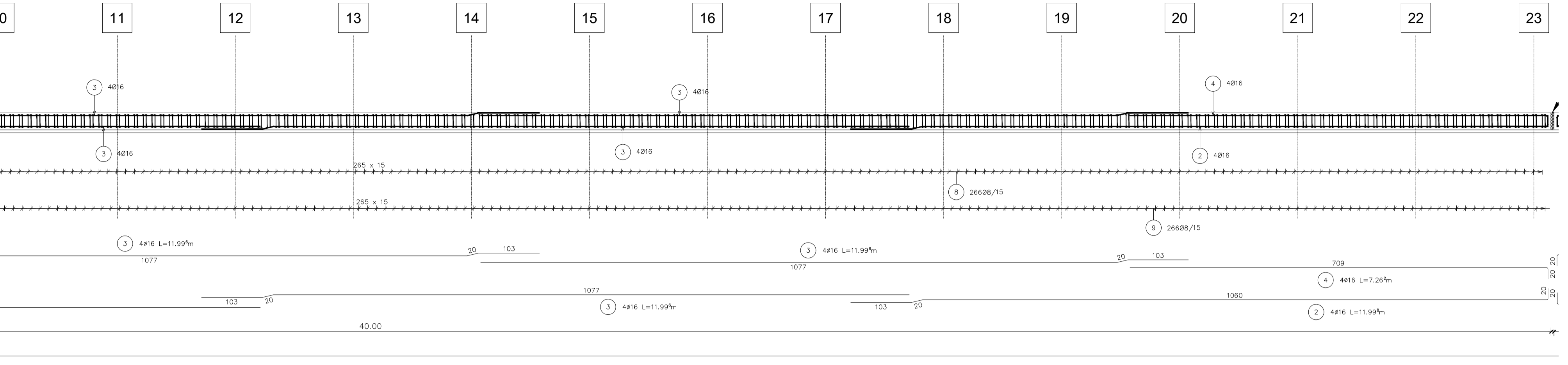

Armarea grinda soclu
Tronson 3 - Sir 24...43

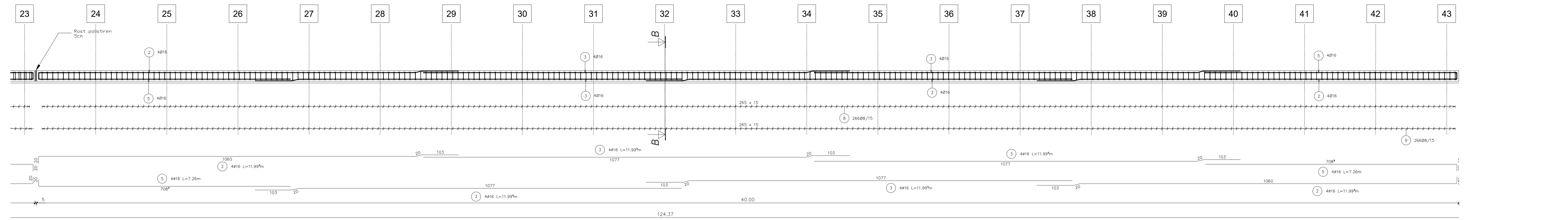

Armarea grinda soclu
Tronson 4 - Sir 44...63

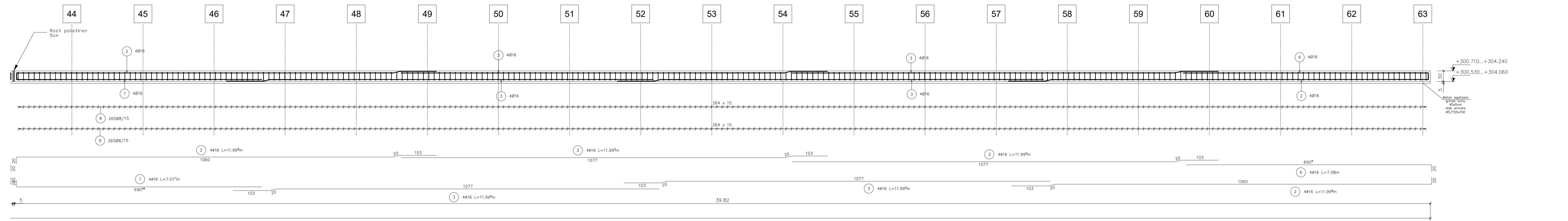

Secțiune A-A

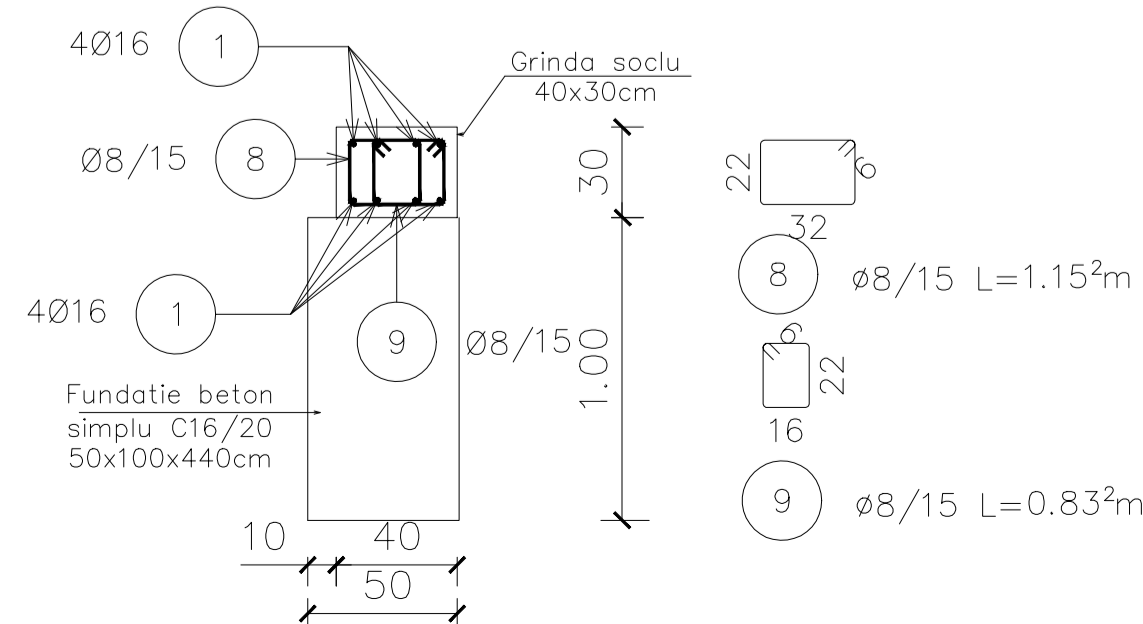

Secțiune B-B

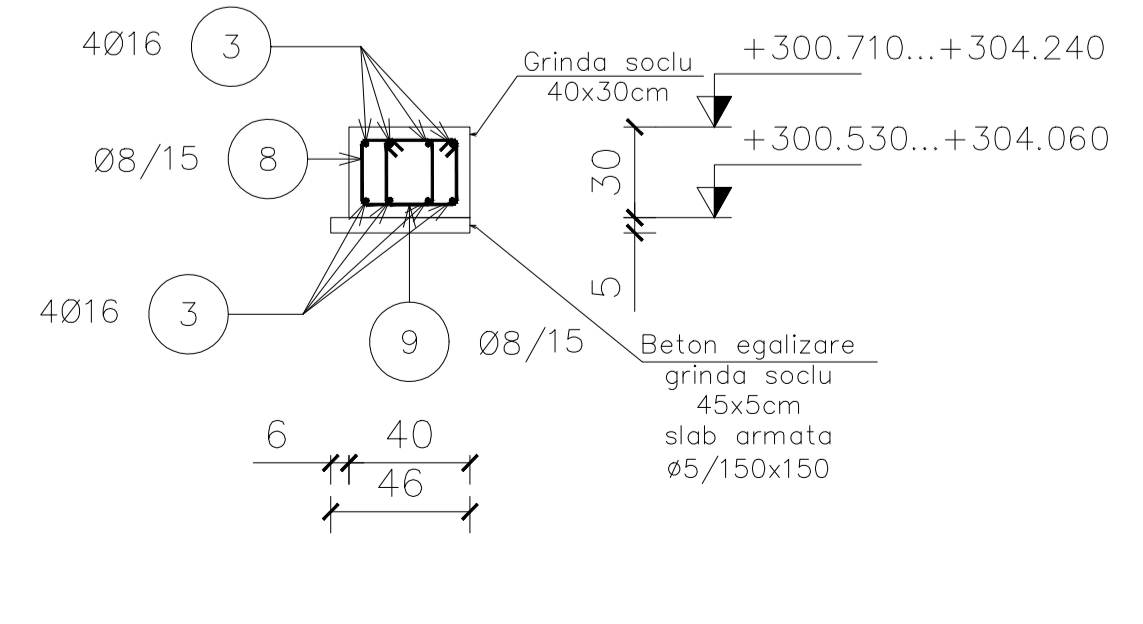

EXTRAS DE ARMARE									
Nr.	Nr. de bare	Total bare	Ø	Longime (m)	Direcție	Nr. de arm.	Total Long. (m)	Ø	Detaliu de bare
1	8	8	Ø16	4.64	7.33	1	37.15	Ø16	4Ø16
2	24	24	Ø15	12.00	18.93	1	227.96	Ø15	Ø8/15
3	48	48	Ø15	12.00	18.93	1	575.82	Ø15	Ø8/15
4	8	8	Ø16	7.26	11.46	1	58.10	Ø16	4Ø16
5	8	8	Ø16	7.26	11.46	1	58.08	Ø16	4Ø16
6	4	4	Ø16	7.08	11.17	1	28.32	Ø16	4Ø16
7	4	4	Ø16	7.08	11.17	1	28.31	Ø16	4Ø16
8	826	826	Ø16	1.15	0.46	1	951.51	Ø16	4Ø16
9	826	826	Ø16	0.83	0.33	1	687.19	Ø16	4Ø16
Masa Totala (kg)		Ø		Masa Totala (kg)		Ø		Masa Totala (kg)	
Ø 37		Ø		Ø 15		Ø 16		Ø 16	
2345		Ø		2345		Ø		2345	

MATERIALE FOLOSITE
OTEL BETON - BS1500s, STNP

BETON -16/20 - beton simplu fundatie grinda soclu
clasa de expunere X0
30/37, 0-31, T3/T4, AC<0.60 - grinda soclu, soclu, beton egalizare grinda soclu
clasa de expunere XC2+XF4+XD1
ac = 5 cm - grinda soclu
ac = 2.5 cm - soclu
ac = 1.5 cm - beton egalizare grinda soclu

Expert		Experiza tehnica nr. /
Verificator / Expert	Nume	Semnatura
		Referat / Experiza nr. / Data
PROIECTANT GENERAL		
S.C. HIGH STANDARDS S.R.L.		
proiectare & proiect management		
HIGH STANDARDS		
Proiectare & Project management		
Specificatie	Nume	Semnatura
Scara	1:25, 1:50	
Beneficiar	MUNICIPIUL MEDIAS	
Proiect nr.	215/A09/2017	
PROIECTANT	ing. Vlad-Mircea LIANCA	
PROIECTAT	ing. Vlad-Mircea LIANCA	
DESEMAT	ing. Vlad-Mircea LIANCA	
Beneficiar	Piața Corneliu Coposiu, nr. 3, mun. Medias, jud. Sibiu	
Format	A1	
Data	mai 2017	
Beneficiar	PROTECȚIE IMOBILE CU PANOURI FONICE PE STR. ST. O. IOSIF	
Beneficiar	PLAN ARMARE GRINDA SOCLU	
Beneficiar	RZ-01	

Proiectul de specialitate este proprietatea intelectuală a firmei S.C.HIGH STANDARDS S.R.L. Medias și a fost realizat la cererea beneficiarului. Reproducerea totală sau parțială a acestuia se poate realiza doar cu acordul scris al proiectantului.